

ARGENTINA – TÜNKERS DE ARGENTINA S.A.
 Vélez Sarsfield 1516 – Quilmes (1879)
 Markt 11
 Smithfield N.S.W 2164
 Tel.: +61 2 749 72870-0
 3385 Markersdorf
 Tel.: +43 2749 42432
 D-07426 Königsee
 per.cj@tuenkers.sk

AUSTRALIA – Romheld Australia Pty. Ltd.
 30/115 Woodpark Rd
 Markt 11
 Smithfield N.S.W 2164
 Tel.: +61 2 749 72870-0
 3385 Markersdorf
 Tel.: +43 2749 42432
 D-07426 Königsee
 per.cj@tuenkers.sk

AUSTRALIA – B-S-D Spanntechnik GmbH
 sales@romheld.com.au

CZECH REPUBLIC – Vertrebsbüro Ost
 office@dsustava.com

CZECH REPUBLIC – Kopla s. r. o.
 per.cj@tuenkers.sk
 21 Woodlands Industrial Park E1, #03-04
 Singapore 757720
 D-07426 Königsee
 Tel.: +49 6251 592-280
 64653 Lorsch
 Am Rosenkothlen 4-12
 Seehofstraße 56-58
 P. A. Ardennes Eméraude
 Rue Henri Faure
 BP 11 09, 08090 Tournes
 France
 Tel.: +33 3 24 52 94 64
 sopap@sopap.com

CHINA – TÜNKERS China
 Technology Co., Ltd. Shanghai
 Building 4, No. 768 Chengyang Road,
 Jiaoding District, Shanghai P. R.
 China, 201702
 Tel.: +86 21 39171070
 info@tuenkers.com.cn
 Other Offices: Changchun, Nanjing, Shenyang
 Whan, Guangzhou, Yantai, Shenyang

CZECH REPUBLIC – Vertrebsbüro Ost
 D-07426 Königsee
 Tel.: +49 6251 592-280
 64653 Lorsch
 Am Rosenkothlen 4-12
 Seehofstraße 56-58
 P. A. Ardennes Eméraude
 Rue Henri Faure
 BP 11 09, 08090 Tournes
 France
 Tel.: +33 3 24 52 94 64
 sopap@sopap.com

INDIA – TÜNKERS Automation India Private Ltd.
 402 Supreme Head Quarters 36
 Mumbai-Pune Bypass
 411008 Baner-Pune
 Tel.: +91 98 60 699190
 jayesh.keskar@tuenkers.com

INDONESIA – DAB Technology Pte. Ltd.
 21 Woodlands Industrial Park E1, #03-04
 Singapore 757720
 D-07426 Königsee
 Tel.: +49 6251 592-280
 64653 Lorsch
 Am Rosenkothlen 4-12
 Seehofstraße 56-58
 P. A. Ardennes Eméraude
 Rue Henri Faure
 BP 11 09, 08090 Tournes
 France
 Tel.: +33 3 24 52 94 64
 sopap@sopap.com

JAPAN – TÜNKERS Japan Ltd.
 Daimyo Create Bldg. 6F
 Chuo-ku, Fukuoka 810-0041 JAPAN
 Tel.: +81 80 83544786
 tomo.kakui@tuenkers.de

MALAYSIA – DAB Technology Sdn Bhd.
 No 9-2B Jalan Bander 10, Pusat Bandar Puchong
 47100 Selangor
 Tel.: +603 8060 9448
 sales@abtech.mt

MOROCCO – SOPAP Automation SAS
 P. A. Ardennes Eméraude
 Rue Henri Faure
 BP 11 09, 08090 Tournes
 France
 Tel.: +33 3 24 52 94 64
 sopap@sopap.com

MEXICO – TÜNKERS DE MÉXICO S.A. DE C.V.
 Prologacion Uragua No. 93 C
 Colonia Sanctorum, Cuautlancingo
 Puebla, C.P. 72730
 Tel.: +52 222 393 5547
 christian.volkman@tuenkers.mx

NETHERLANDS – TÜNKERS Maschinenbau GmbH
 Am Rosenkothlen 4-12
 D-40880 Ratingen
 Tel.: +49 2102 4517-0
 peter.czajkowskij@tuenkers.de

POLAND – TÜNKERS Slovakia s.r.o.
 Hoengonova 26
 SK88101 Bratislava
 Bratislava, Rozmarinová 225
 Tel.: +48 660 055 225
 jafostaw.rozmarin@tuenkers.sk

ROMANIA – TÜNKERS Maschinenbau GmbH
 www.tuenkers.sk

ROMANIA – TÜNKERS Maschinenbau GmbH
 55068 Sibiu, Romania
 Tel.: +40-752 184 548
 jafostaw.rozmarin@tuenkers.sk

RUSSIA – WEST-RU
 Novikova-Privoja Str. 4 office 407
 Moscow 109316
 Office 315, Sibirskij Proezd 2-27
 Tel.: +7 495 775 - 0377

SERBIA – TÜNKERS Maschinenbau GmbH
 55068 Sibiu, Romania
 Tel.: +40-752 184 548
 trajan.moga@tuenkers.sk

SLOVAKIA – TÜNKERS Slovakia s.r.o.
 Twin City C
 Mlynské nivy 16
 SK82109 Bratislava
 Tel.: +421 905 564 691
 jural.rampasek@tuenkers.sk

SLOVENIA – TÜNKERS Maschinenbau GmbH
 Hoengonova 26
 SK88101 Bratislava
 Bratislava, Rozmarinová 225
 Tel.: +48 660 055 225
 jafostaw.rozmarin@tuenkers.sk

SOUTH AFRICA – Demcon (Cape) cc
 PO Box 15237
 ZA-60110 Emerald Hill/Port Elizabeth
 Tel.: +27 41 4847411
 demcon@demcon.co.za

SOUTH KOREA – JC Systems Co. Ltd.
 #405 Ace Highend 9Cha, 233,
 Gasan digital 1-ro, Geumcheon-gu, Seoul
 Tel.: +82 70 7012089
 jcho@chochol.com

SPAIN – TÜNKERS IBERICA, S.L.
 c/ Enric Prat de la Ribera, 14b
 08830 Sant Boi de Llobregat (Barcelona)
 Tel.: +34 93 3952827
 lunkers@tuenkersiberica.com

SWEDEN – BERGA MASKIN
 SE-646 93 GNESTA
 Tel.: +46 158 31112
 info@berga-maskin.se

THAILAND – DAB Technology Co., Ltd.
 H20 42/415 Kanchanapisak Rd.
 Dokmai, Praveh,
 Bangkok 10250
 Tel.: +66 97 072 8972
 rochaya.jaranyant@tuenkers.de

TURKEY – Cava Makina
 İmes Sanayi Sitesi E 503
 34776 Ümraniye / İstanbul
 Tel.: +90 216 3809280
 alp.verna@cava.com.tr

UK – TÜNKERS-EXPERT UK Ltd.
 Unit 5, Ham Lane,
 West Midlands,
 Kingswinford,
 DY7 7JR
 Tel.: +44 (0) 1384 287690
 neal.judge@tuenkers.de

USA – TÜNKERS-Mastech
 36200 Mount Road
 Sterling Heights, MI 48312
 Tel.: +1 734 744 5990
 christian.heyer@tuenkers.com

VIETNAM – DAB Technology Pte. Ltd.
 21 Woodlands Industrial Park E1
 #03-04
 Singapore 757720
 enquiny@dabtech.net

BRASIL – Tünkers do Brasil Ltda.
 Avenida Casa Grande, 850 – Galpão 6, 11 e 13
 Bairro: Casa Grande, 850 – Galpão 6, 11 e 13
 Tel.: +55 11 4056-3100
 comercial@tuenkers.com.br

CANADA – TÜNKERS-Mastech
 36200 Mount Road
 Sterling Heights, MI 48312
 Tel.: +1 734 744 5990
 christian.heyer@tuenkers.com

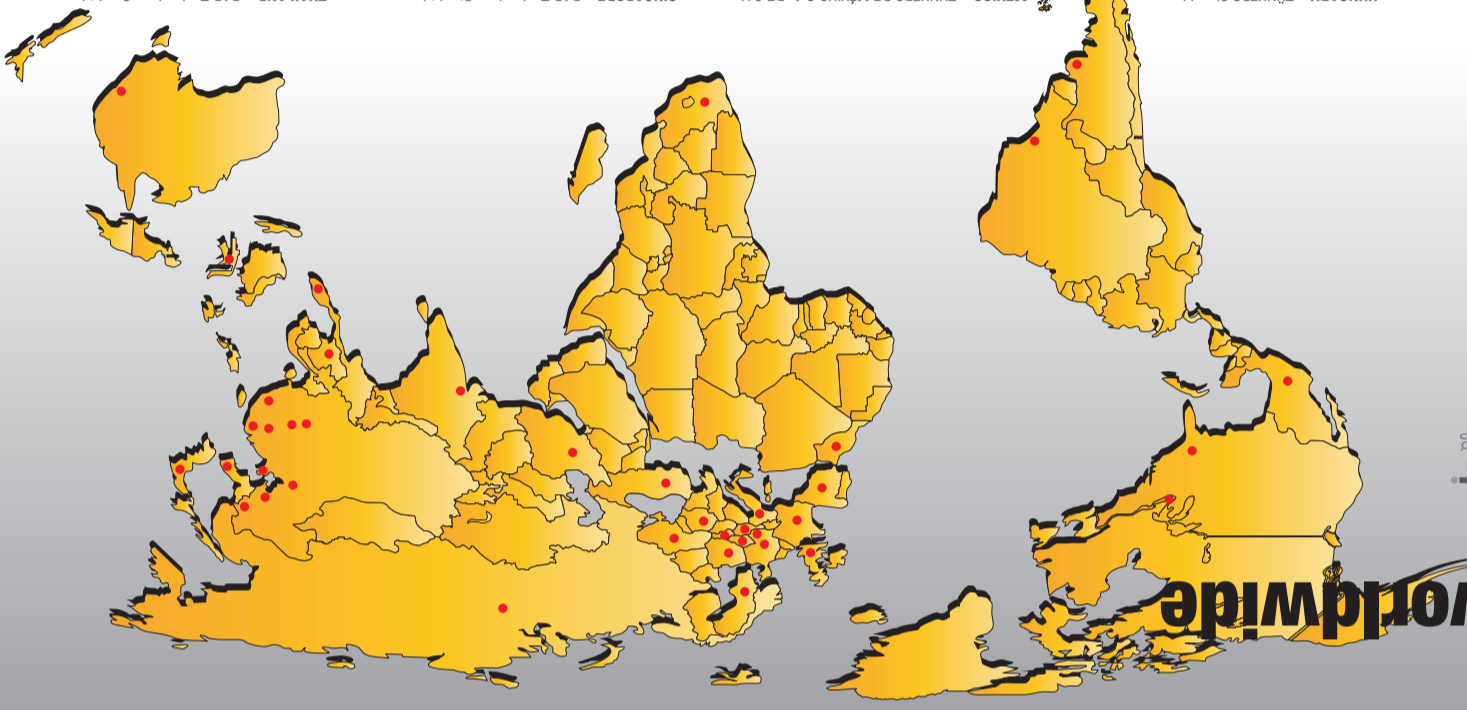

At your service - worldwide

TÜNKERS Ingenuity in series.

EXPERT Indexing & Positioning

SOPAP Automation.

HELU Welding technology

TÜNKERS Maschinenbau GmbH
 Am Rosenkothlen 4-12
 Seehofstraße 56-58
 40880 Ratingen
 Germany
 Tel.: +49 2102 4517-0
 info@tuenkers.de
 www.tuenkers.de

EXPERT-TÜNKERS GmbH
 Seehofstraße 56-58
 64653 Lorsch
 Germany
 Tel.: +49 6251 592-0
 info@expert-tuenkers.de
 www.expert-tuenkers.de

SOPAP Automation SAS
 P. A. Ardennes Eméraude
 Rue Henri Faure
 BP 11 09, 08090 Tournes
 France
 Tel.: +33 3 24 52 94 64
 info@heiu.de

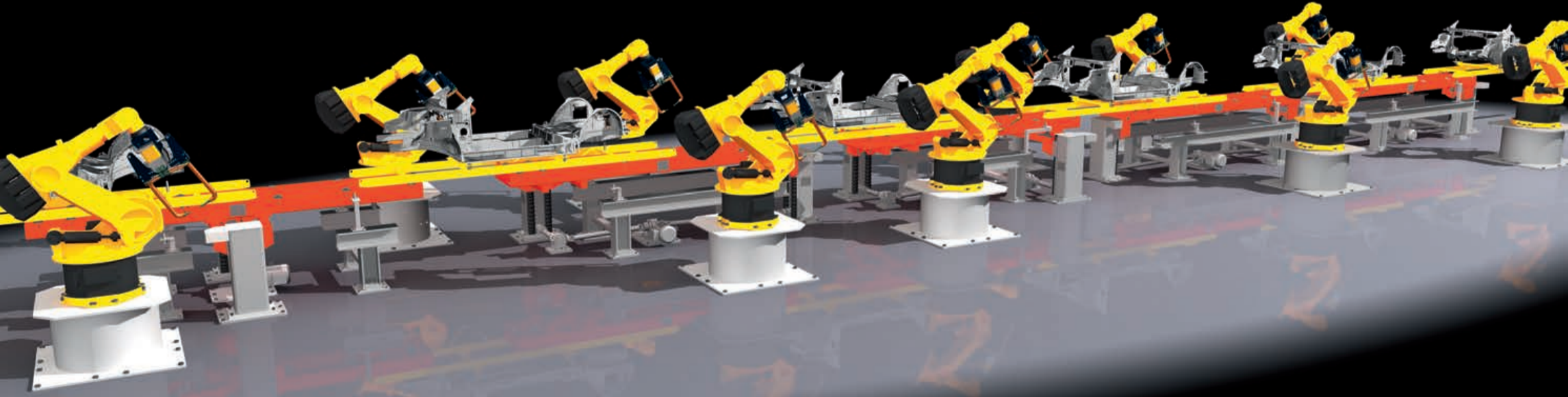

TRANSPORTING

It is our understanding that the transport function includes electro-mechanical systems taking over e. g. the transport of a complex assembly group such as a door, side panels or the entire car body in car body construction. The transport distances are set up in lines and designed as walking beam system, also called lift shuttle system, with a central drive. Lift powered rollerbeds equipped with decentralised drives are a further development offering new dimensions in terms of performance data and also more layout flexibility as regards possible lengths of inter-linking.



Cam-Driven Lifter providing Optimum Lifting Profile

One of the essential characteristics of lift conveying systems used in body construction is the requirement for a smooth component pick-up to reduce noise emissions and wear and tear of the lift and the component.

This lifting profile is realized at zero speed at the point of transfer, high acceleration and braking processes provided by the EXPERT-TÜNKERS barrel cam, disposing of an adequately machined motion profile as standard. For cams with fixed gradient, so-called flexible cams, the desired lifting profile is achieved via the servo-control.

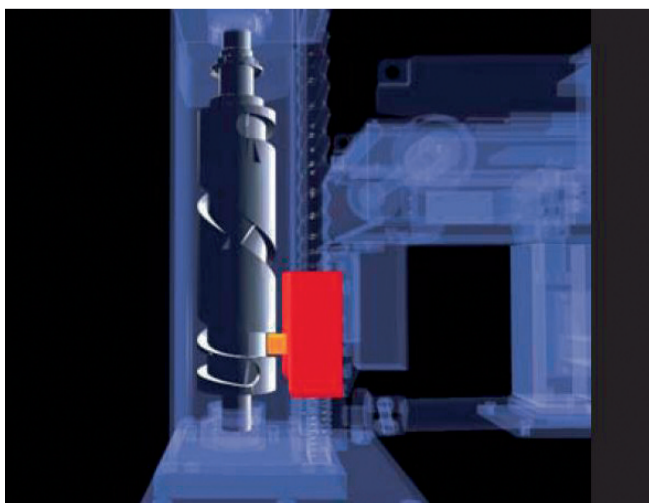

Soft-Touch Pick-up

Lift Shuttle System

The barrel cam is the core element of lift shuttle systems equipped with central drives.

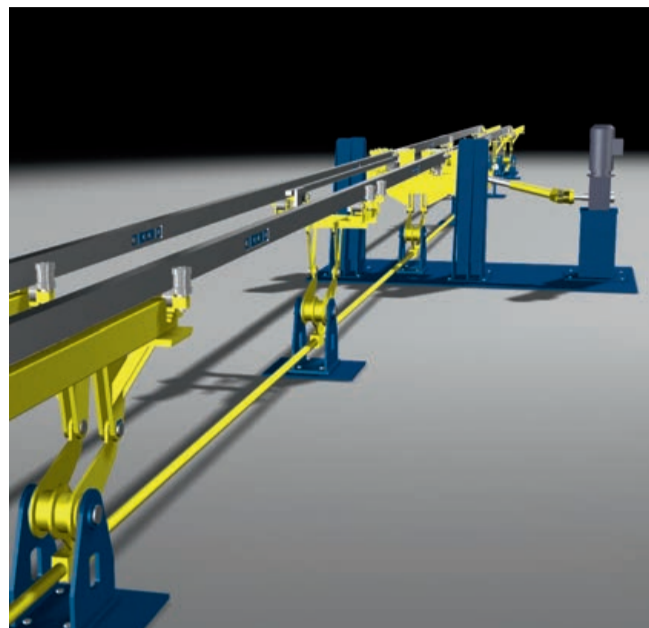

Lift Column with Cam Technology!

Combined with a robust longitudinal guide, the barrel cam constitutes the basis of EXPERT-TÜNKERS lift columns. Synchronized via a cardan axis, two lift columns driven by a central geared motor form a lift station.



Monorail Shuttle

By means of horizontal linear axes and two synchronized lift columns, simple conveyor lines such as the monorail shuttle system can be built. They are particularly suited for the transport of smaller components with lower loads.



Lift Powered Rollerbed

Two lift columns combined with one EXPERT-TÜNKERS roller conveyor form the centre-piece of the EXPERT-TÜNKERS lift powered rollerbeds.

This skid conveyor system is designed to transport complete car bodies or undercarriages with maximum loads of 2 to.

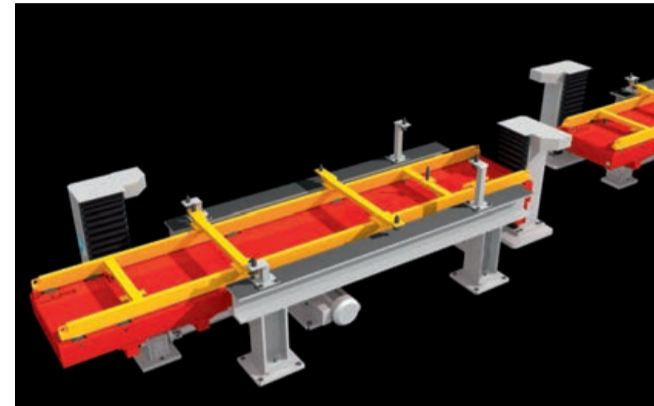

Buffer/Transverse Transport etc. Additional Transport Solutions

The transport lines are supplemented by coordinated construction systems such as buffer segments, transverse conveyors, ring buffers, lifting rotary units and level lifter, feeding the component into the higher-level conveying technology. This technology is also used in heavy-duty systems to traverse complete fixtures or robot systems (7th axis).

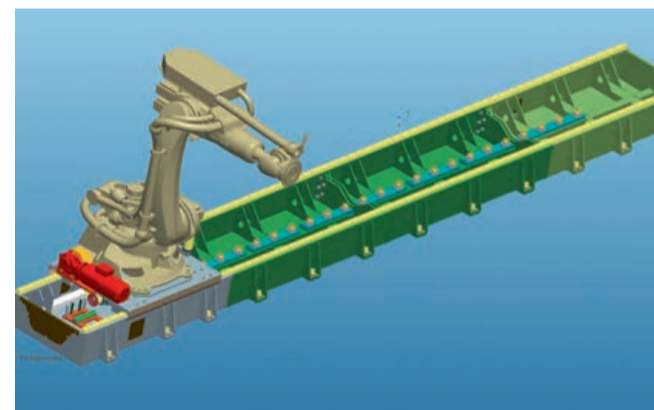

Shuttle beats Robot – EXPERT transport systems are more cost-efficient than robot lines

Even though in the robot era cell and/or station transport are increasingly realized by robot handling, EXPERT-TÜNKERS transport lines provide economic benefits not only when heavy and large-dimensioned components are transported. This is particularly evident when comparing the controllable drives. For a lift shuttle designed for 8 stations two drives (1 x lifting and 1 x traversing) are required. The alternative solution with 8 robots (6-axes-system) requires still 48 drives – admittedly, with lower flexibility but optimized cycle time. With this in mind, EXPERT transport systems are also an instrument to streamline layout complexity and therefore to reduce costs.

TRANSPORTING

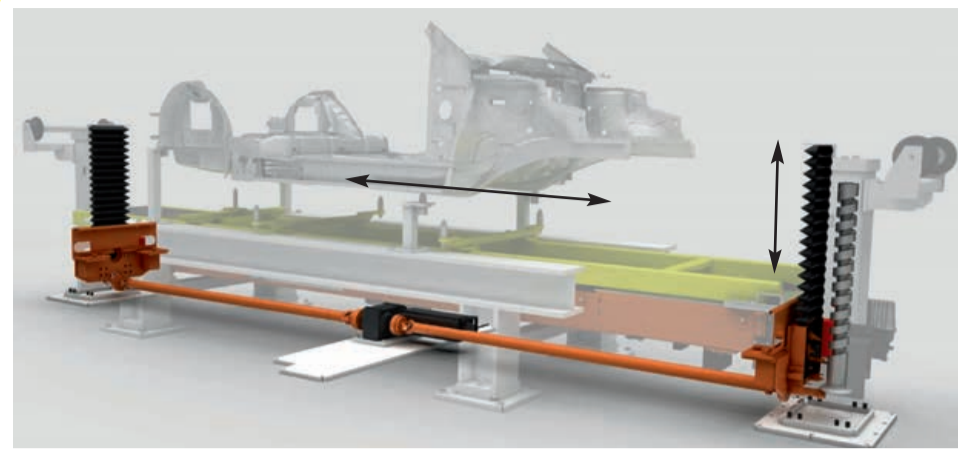

Lift Powered Rollerbed

Conveying system for car body-frames for precise and pinpoint positioning of skids with car bodies or car body components in flexible station design in non-chained operation.

- Secure and rapid transport
- Soft component transfer
- Flexible definition of pick-up position
- Compact design
- Extreme ease of maintenance
- Long service life
- Flexible arrangement of lift columns for optimized robot accessibility to the component

Customer load (Skid + car body)	200-2.000 kg
Horizontal stroke	4.000-10.000 mm
Vertical stroke	300-1.200 mm
Cycle time Lifting/traversing/lowering	≥ 7 sec

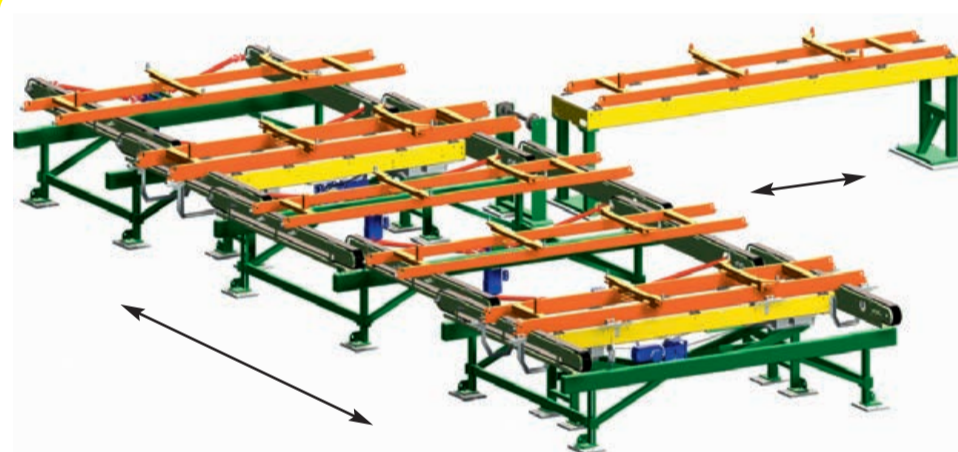

Skid Transverse Conveyor

- Modular horizontal accumulator for skids with car body
- Parts buffer for decoupling production lines
- Flexible layout design

Customer load (Skid + car body)	200-2.000 kg
Transversal stroke	2.000-10.000 mm
Vertical stroke	50-200 mm



Level lifter

Lifting device for complete car bodies from the welding plane to the higher-level conveying technology.

Customer load (Skid + Car body)	150-1.500 kg
Vertical stroke	4.000-8.000 mm

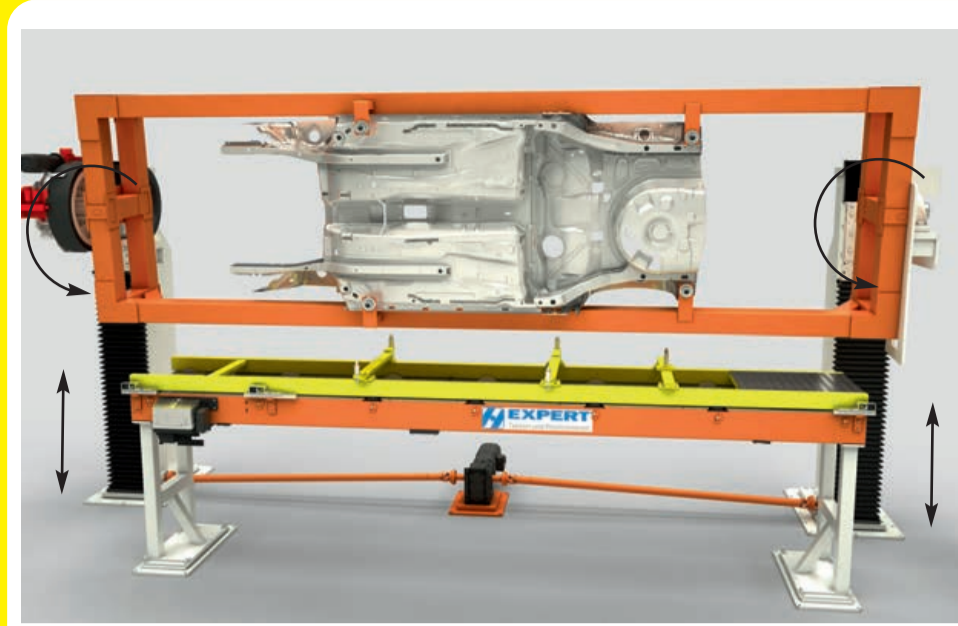

Lifting Rotary Unit

Lifting rotary device for handling car bodies

- Fields of application e.g. inspection station, rework stations, setting of weld studs
- Modular design consisting of EXPERT standard components with cam-driven lifting unit and trunnion drive
- Minimum space requirements

Customer load (Car body + Holding frame)	50-3.000 kg
Vertical stroke	1.200-2.800 mm
Stroke time	3-10 sec
Rotating angle	flexible

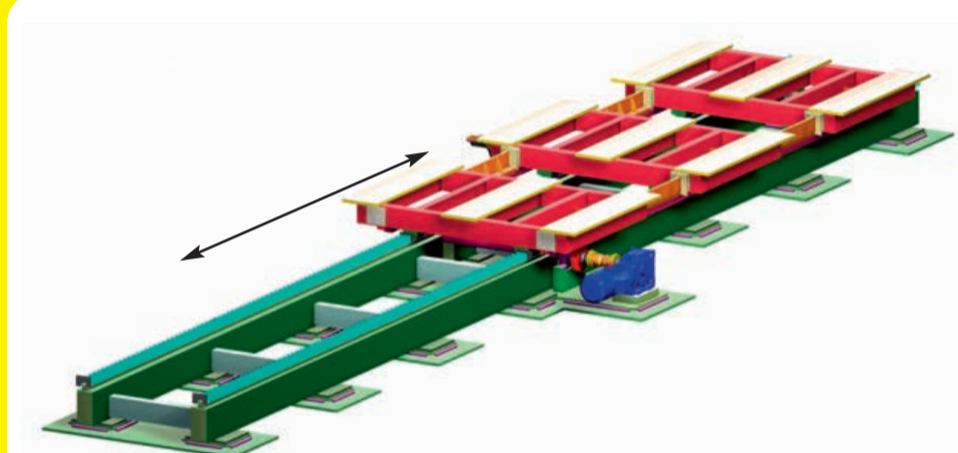

Tool Traversing Unit

Tool traversing unit for horizontal traversing of heavy fixtures Use in flexible production lines: e. g. for cross traversing of fixtures for various car types below the centre line.

Customer load	500-5.000 kg/ Fixture
Horizontal stroke	2.000-8.000 mm



Ring Buffer

- Modular horizontal vertical accumulator for skids with car body
- Maximum storage capacity with minimum space requirements
- Parts buffer for decoupling production lines
- Flexible layout design

Customer load (Skid + car body)	200-2.000 kg
Transversal stroke	2.000-10.000 mm
Vertical stroke	1.500-2.800 mm

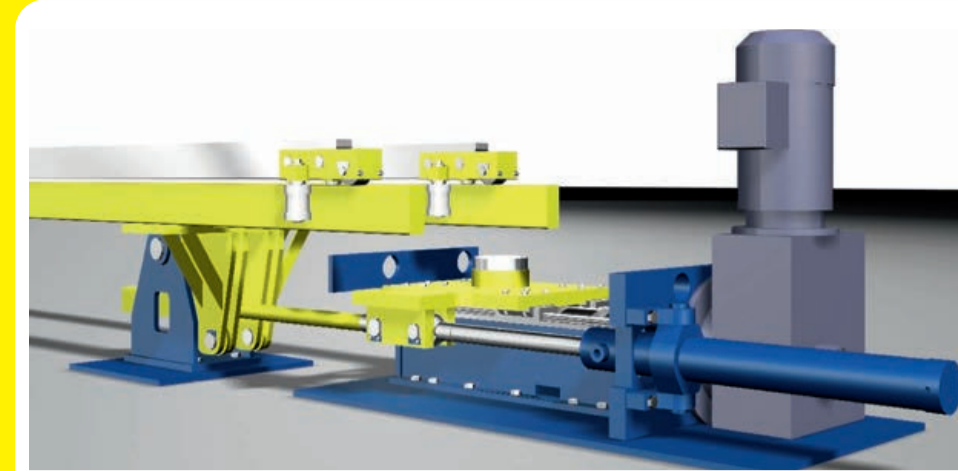

Lift Shuttle

Conveying system for body-framework for precise and pinpoint positioning of car bodies or automotive body parts in chained operation.

- Secure, precise working and rapid transport system with lifting and positioning axis for large components
- Synchronous component transport through all stations
- Simple design, only one central drive for lifting and conveying
- End position mechanically locked via gate, overrunning the end position is impossible

Customer load	50-500 kg/station
Number of stations	3-15
Horizontal stroke	3.000-8.000 mm
Vertical stroke	300-1.200 mm
Cycle time Lifting/traversing/lowering	≥ 10 sec

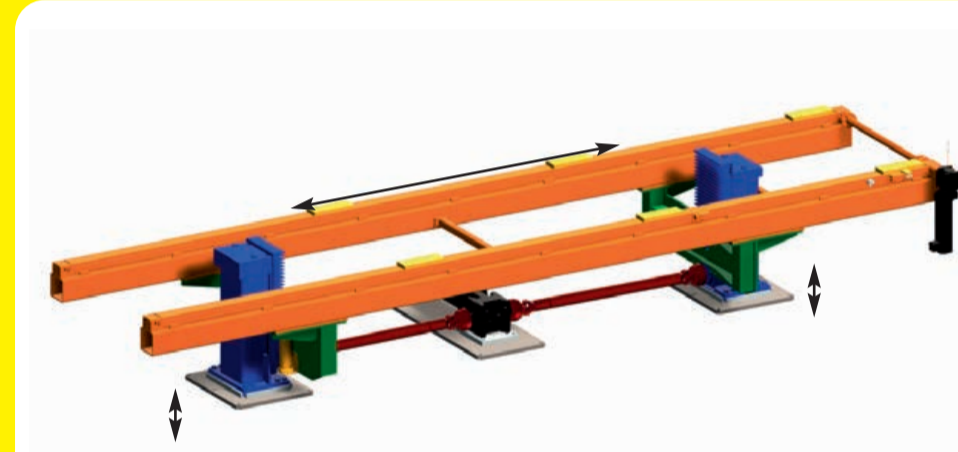

Monorail-Shuttle/Duorail-Shuttle

Conveying system for short traverse paths and smaller components

- Transport system for body panels, e.g. doors and flaps
- Fields of application e.g. application of adhesive, clinching
- Modular, flexible design
- Cost-efficient solution for the transport of small components

Customer load	10-250 kg
Horizontal stroke	1.000-5.000 mm
Vertical stroke	300-1.000 mm
Cycle time Lifting/traversing/lowering	≥ 5 sec

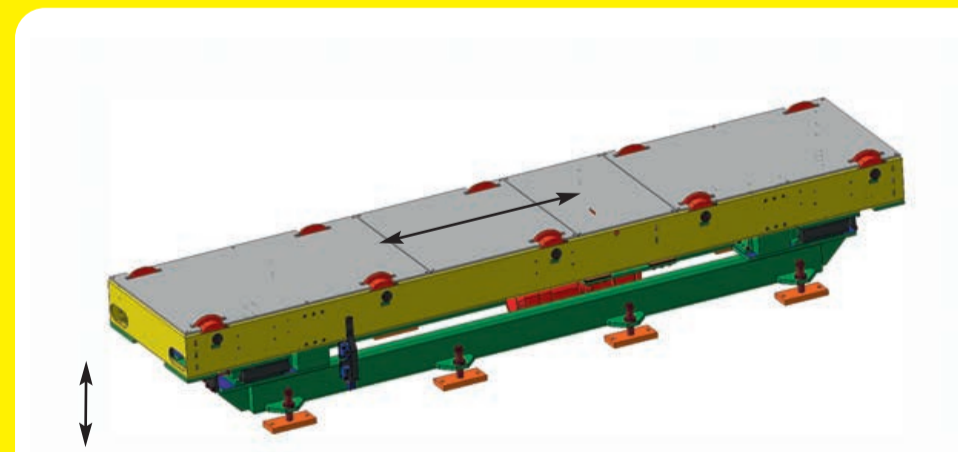

Eccentric Lift Unit

Lift system for short lifts with moderate transport times

Customer load	200-2.000 kg
Vertical stroke	50-200 mm
Stroke time	≥ 2 sec

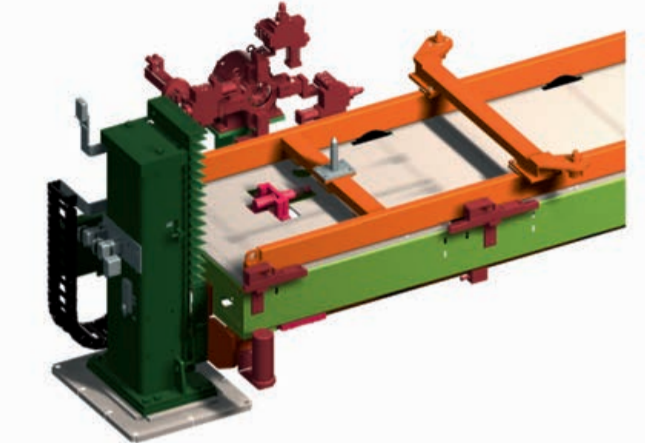

All-Electric Lift Powered Rollerbed

All-electric lift powered rollerbed with laser positioning of the skids and flexible ground clamping technology

- Time-saving, approx. 1 second!
- Cycle time less than 7,5 sec.!!!
- Precise skid positioning via laser distance measurement
- Variable skid positioning on the roller conveyor is possible
- Electric stopper to protect against overflow
- Electric fine positioning of skids
- No pneumatics, i. e. no valve island required!

Customer load (Skid + car body)	200-2.000 kg
Horizontal stroke	4.000-10.000 mm
Vertical stroke	300-1.200 mm
Cycle time Lifting/traversing/lowering	≥ 7 sec

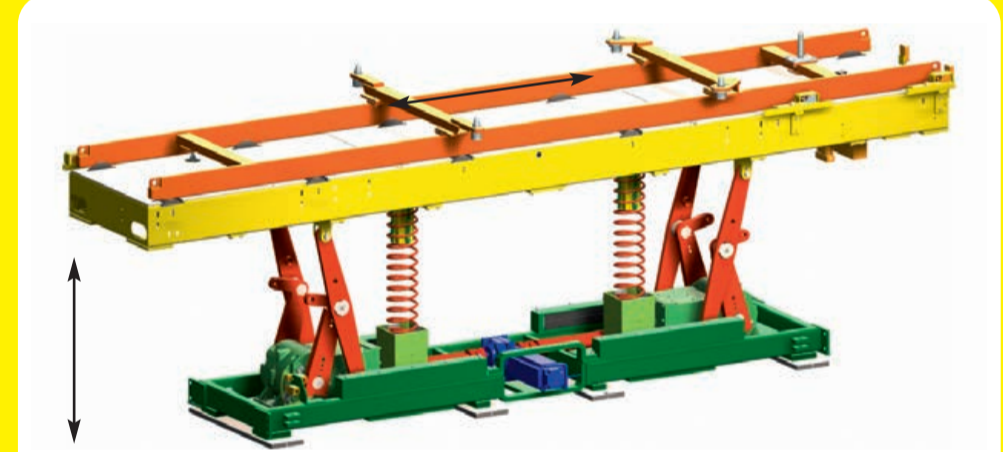

Double-box Lift

Roller conveyor lift in flat design with integrated spring-loaded accumulating system

- 30% less energy consumption
- Minimum space requirements
- No disrupting edges for robot welding guns
- Soft component transfer
- Flexible definition of pick-up positions

Customer load (Skid + car body)	200-1.000 kg
Horizontal stroke	4.000-10.000 mm
Vertical stroke	200-800 mm
Cycle time Lifting/traversing/lowering	≥ 6 sec